

CEDAR CREEK
OHL
KFC ENGINEERING
STRUCTURAL
SALUS O'BRIEN
MECHANICAL/ELECTRICAL

RS
drawn by
RS
checked by
date 10/29/2024
revisions
Addendum #1 11/20/2024

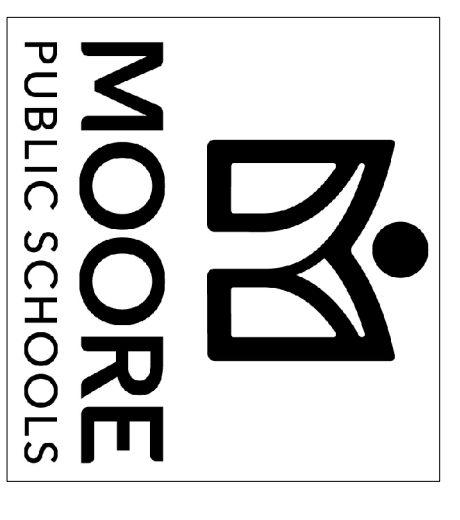

CHILD CARE FACILITY
201 N. EASTERN AVE.

Sheet No:
FS101

OWNERSHIP USE OF DOCUMENTS:
AGE EXPRESSLY RESERVES ITS
COPYRIGHT AND OTHER PROPERTY
RIGHTS OF ALL PLANS AND DRAWINGS
DESIGNED AND/OR PRODUCED. PLANS
AND DRAWINGS ARE NOT TO BE
REPRODUCED IN ANY FORM OR MANNER
WITHOUT THE EXPRESSED WRITTEN
CONSENT OF ACP.

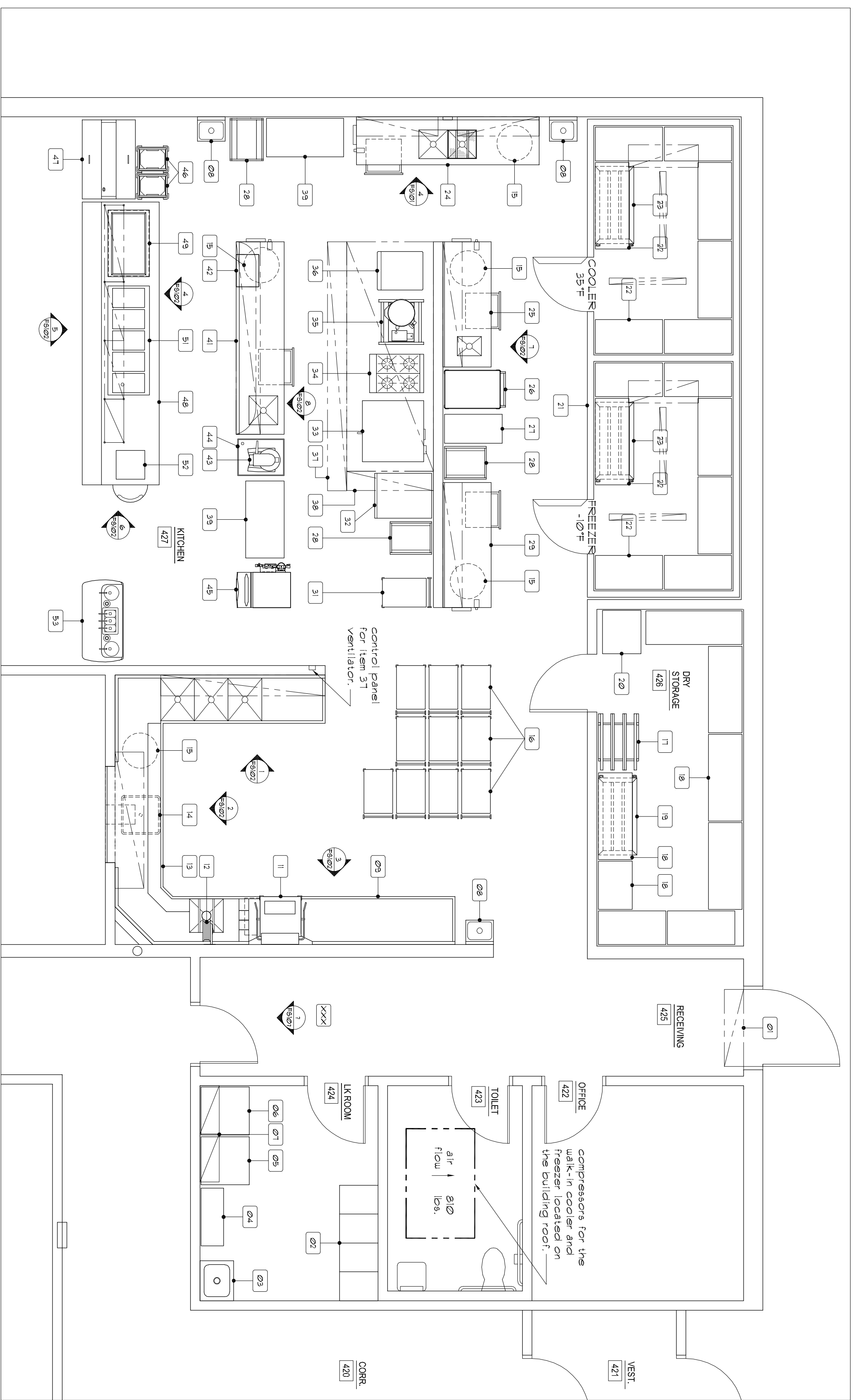

1 FOODSERVICE EQUIPMENT ARRANGEMENT PLAN
1/4" = 1'-0"

NO.	DESCRIPTION - PHASE I
01	AIR CURTAIN
02	LOCKERS
03	HOCKERS
04	CHEMICAL STORAGE SHELVING
05	WASHER BY THE OWNER
06	DRYER BY THE OWNER
07	WALL MOUNTED LINEN SHELVES
08	CAN DISH
09	CAN DISH TABLE
10	NUMBER NOT USED
11	VENTILATED DISHWASHER WITH BOOSTER HEATER
12	SOILED DISHTABLE
13	WALL MOUNTED HOSE REEL
14	TOILET SOAP SINK
15	TOILET
16	MEAL TRANSPORT CART'S
17	CAN RACK
18	STORAGE SHELVING
19	MOBILE DINNAGE RACK
20	MOBILE BECAD RACK BY THE VENDOR
21	WALK IN STORAGE SHELVING
22	WALK IN STORAGE SHELVING
23	MOBILE DINNAGE RACK
24	FREEZE TABLE
25	ALLEGEY LOCK TABLE
26	ALLEGEY LOCK TABLE
27	ALLEGEY LOCK TABLE
28	MEAL ASSEMBLY TABLE
29	NUMBER NOT USED
30	NUMBER NOT USED
31	MOBILE UTILITY CART
32	MOBILE FOOD/HOT CABINET
33	MOBILE COOLING RACK
34	MOBILE RANGE
35	12 GALLON TILTING KETTLE
36	CONVECTION STEAMER
37	VENTILATOR
38	ME BUREAU
39	ME BUREAU
40	NUMBER NOT USED
41	NUMBER NOT USED
42	COOKS TABLE
43	MICROWAVE
44	20 QUART MIXER
45	MEAL SERVER STAND
46	MOBILE TRAY DISPENSER
47	MOBILE MILK COOLER
48	SERVING COUNTER
49	DROPPIN COLD FOOD WELLS
50	DROPPIN COLD FOOD WELLS
51	POS BY THE OWNER
52	MOBILE CONDIMENT COUNTER
53	MOBILE CONDIMENT COUNTER

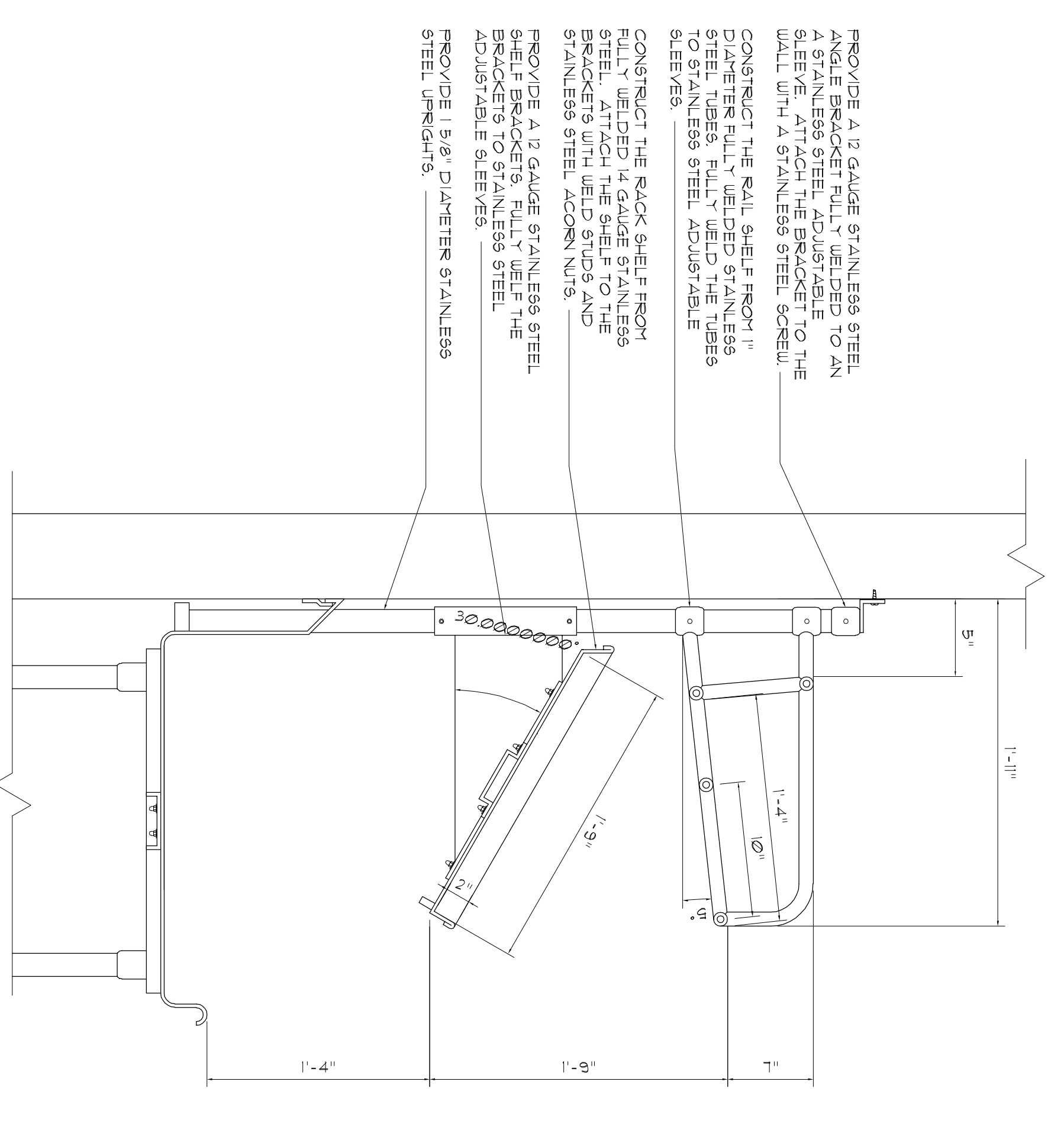

2 SECTION - SOILED DISHTABLE RACK & RAIL SHELVES
NO SCALE

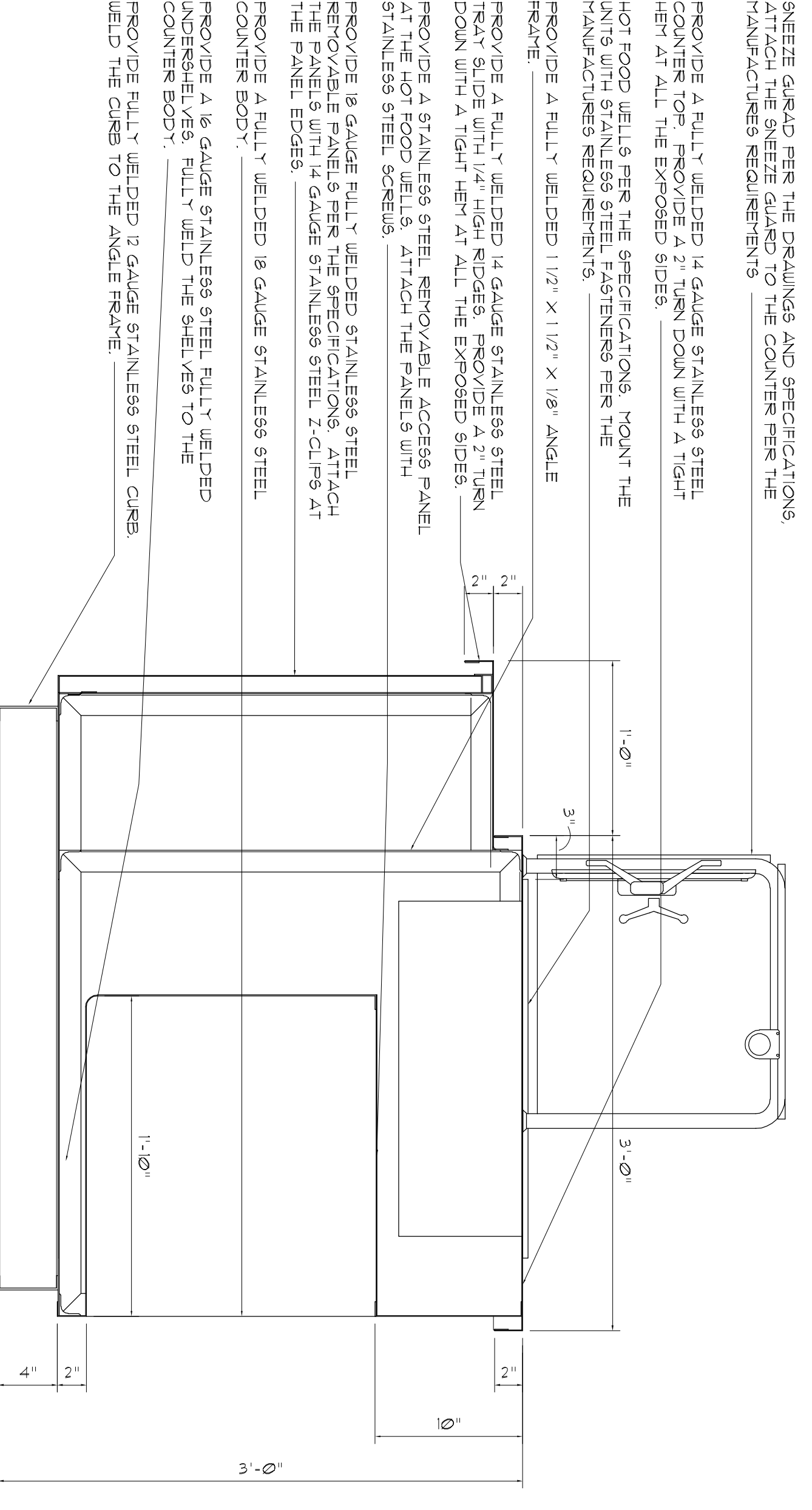

3 SECTION - SERVING COUNTER
NO SCALE

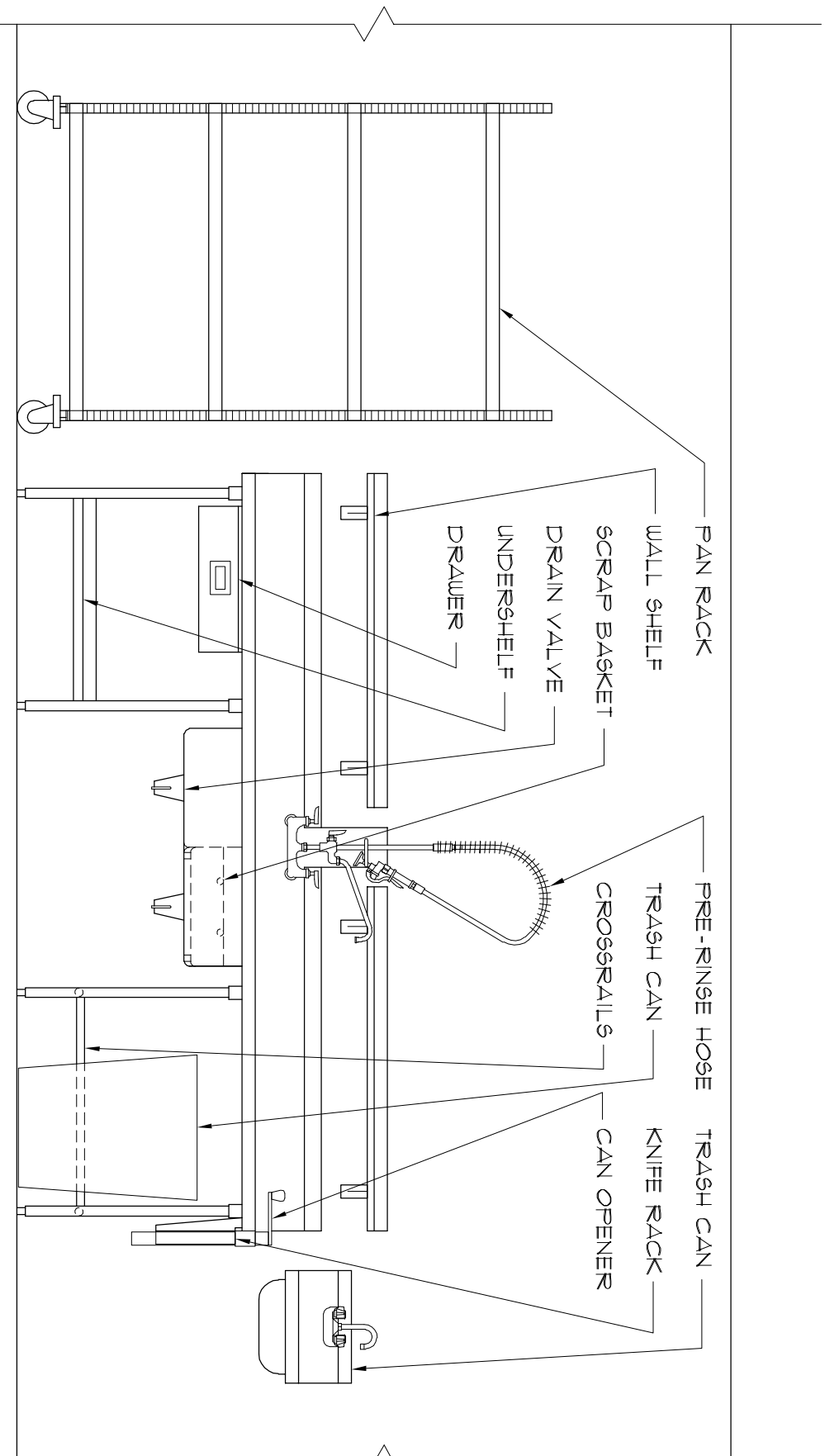

4 ELEVATION
NO SCALE